

STANNAH LIFTS LTD
TECHNICAL BULLETIN

INFORMATION ONLY

For the Attention of : Service Engineers, Training Dept

Date : 18/11/2009

Product : MRLi Passenger Lifts

Subject : Pawl Device Retrofit Kits on lifts with 2 car entrances

Pages : 1

Originator : Stannah Lifts Ltd, Anton Mill, Andover, Hants SP10 2NX 01264 339090

TB87 rev A = Change to SRA wiring

Following the original issue of this bulletin an error has been found on drawing 9333/729 revision C whereby the SRA relay wiring was shown incorrectly (see diagram below).

Note: the schematic diagram supplied (1009239 rev A) shows the correct wiring of the SRA relay.

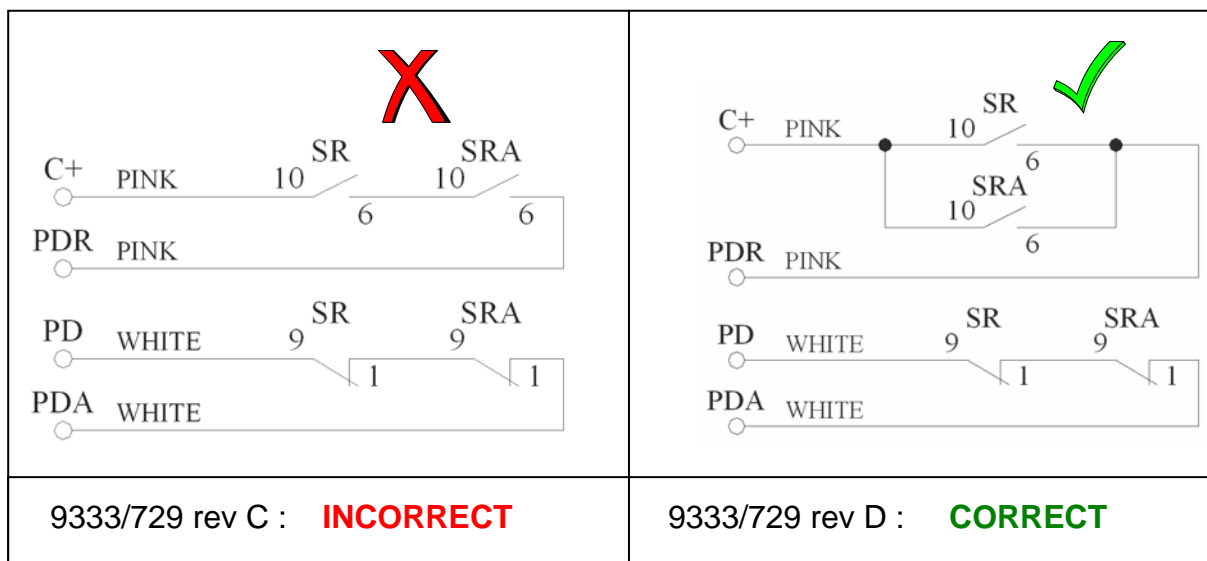

Action Required:

1. SRA relay on MRLi's with 2 car entrances to be wired in accordance with the above diagram (or 9333/729 revision D or 1009239 rev A).
2. A paper copy of 9333/729 revision D must be stored on site (2 car entrances only).
Earlier revisions of 9333/729 and 1009239 should be discarded.

No extra parts are required - this is a wiring change only.

Attachment:
 - 9333/729 rev D

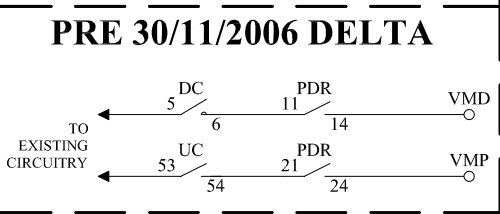
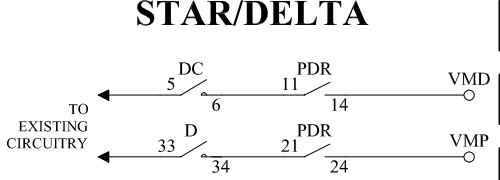
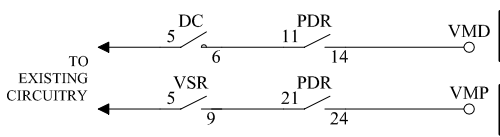
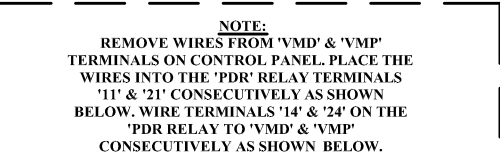
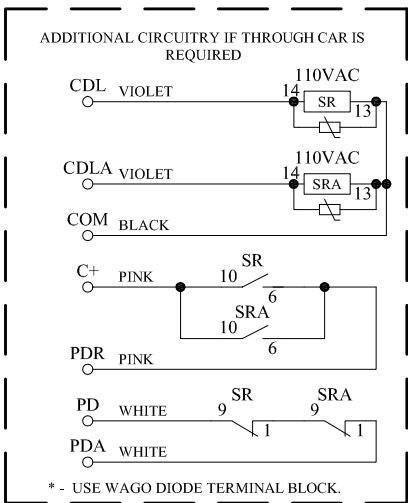
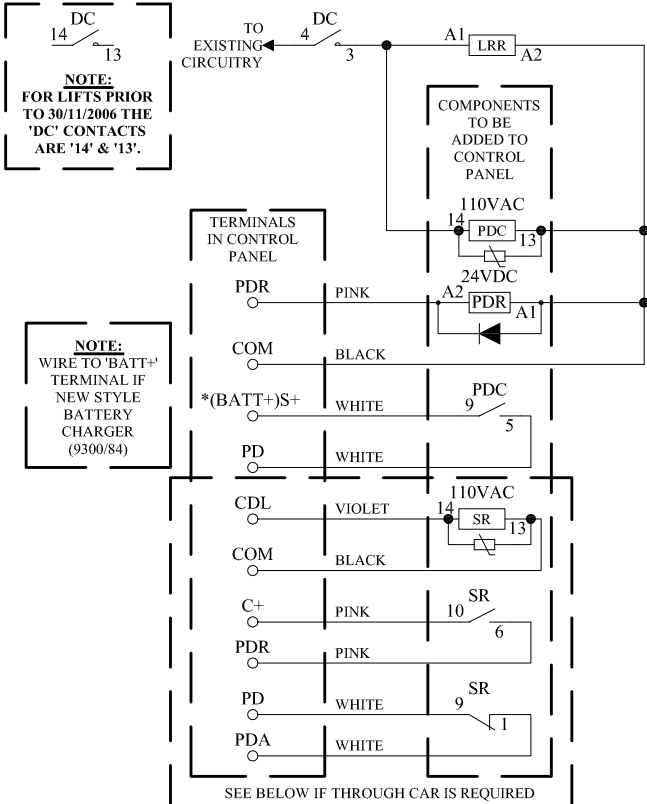
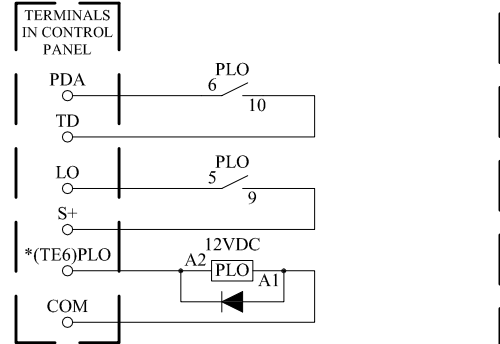
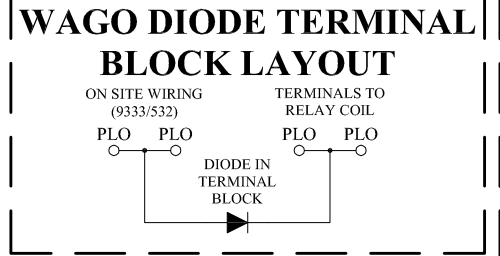
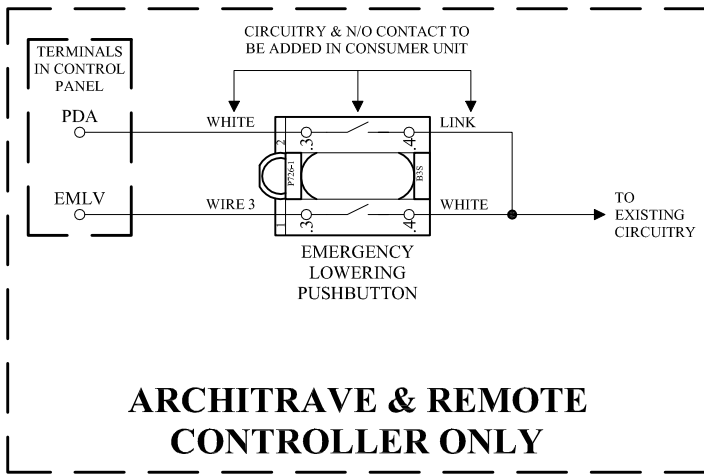

**NOTE:
ADDITIONAL WAGO TERMINALS
LABELLED 'PDR', 'PDA' & 'PD' REQUIRED.**

RELAY & CONTACTOR DATA
IMO RELAY 110VAC
PDC, SRA & SR
IMO RELAY 24VDC
PDR

REV D: 'SRA' RELAY CONTACTS '10' & '6' CHANGED TO BE WIRED IN PARALLEL WITH 'SR' CONTACTS '10' & '6'. NOTE ADDED TO 'DC' CONTACTS. 17/11/2009 SAJ.
REV C: DIODE TERMINALS REMOVED. 'SRA' RELAY ADDED 10/11/2009 SAJ.
REV B: 'BATT+' NOTE ADDED. PLO RELAY CONTACT NUMBERING CHANGED 13/10/2009 SAJ.
REV A: LINK BETWEEN 'PDA' & 'TD' REMOVED, NOW WIRED THROUGH 'PLO' RELAY, WAGO DIODE TERMINAL BLOCK LAYOUT ADDED, ALONG WITH ADDITIONAL CIRCUITRY FOR THROUGH CAR 14/09/2009 JN

NAME: S. JACKSON	DATE: 24/03/09
CHECKED: G. COOPER	DATE: 24/03/09
NEXUS ADDITIONAL CIRCUITRY PAWL DEVICE PANEL MODIFICATION DETAILS	
	HEAD OFFICE: Anton Mill Andover Hampshire SP102NX England
Tel: 01264 339090 Fax: 337942	
DRAWING NO: 9333/729	REV: D